

**MOSA M12 SC female 90° 3LED field-wireable (IDC)**4-pol. 0.25...0.5mm<sup>2</sup>

Female 90°

The resistance to aggressive media should be individually tested for your application. Further details on request.

M12, 4-pole

3× LED (PNP)

IDC terminals

(NPN) on request

Stainless steel 1.4305 (V2A) PTFE coated

Connection cross section: 0.25...0.5 mm<sup>2</sup>

Art-No. 7005 - M12 Lite - (plastic hexagonal screw) on request

Plastic housings with good resistance against chemicals and oils.

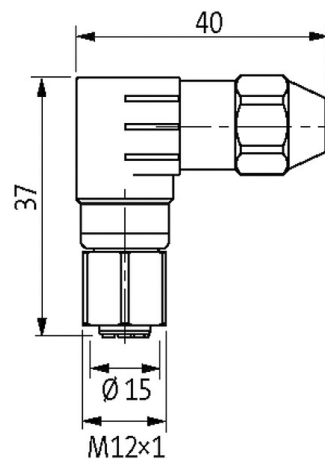
[Link to Product](#)**Illustration**

Product may differ from Image

**Form**

Form 12691

**General data**

Pollution Degree 3

Temperature range -25...+85 °C

Material (gasket) FKM

**Technical Data**

Operating voltage 24 V DC ±25%

Rated surge voltage	0.8 kV
Operating current per contact	max. 4 A
Material group	IEC 60664-1, category III
Connection cross section	0.25...0.5 mm <sup>2</sup> (conductor diameter min. 0.1 mm)
Coding	A-coded
Sealing range (cable Ø)	4...5.1 mm
Wire isolation	PVC, PP, TPE
LED display	LED (green): Power / LED (yellow): (S1) / LED (white): Signal (S2)
Outer wire Ø	1.2...1.6 mm
Locking of ports	Screw thread (M12×1 mm) recommended torque 0.6 Nm, self-securing
Protection	IP67 inserted and tightened (EN 60529)
Locking material	Stainless steel 1.4305 (V2A) PTFE coated

**Commercial data**

country of origin	DE
customs tariff number	85366990
EAN	4048879467889
eClass	27279221
Packaging unit	1

**Sketch**

Female

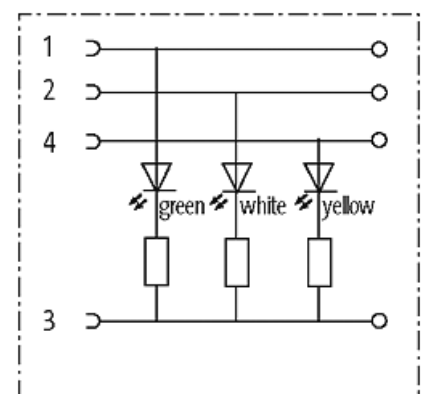
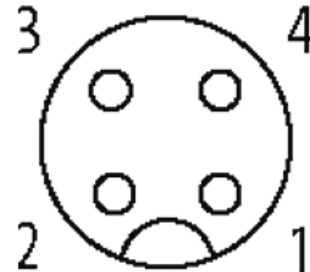

Product may differ from Image